

# **The U. S. Army Yuma Proving Ground 900-kVA Photovoltaic Power Station**

Roch Ducey, U.S. Army Construction Engineering  
Research Laboratories, Richard Chapman, Sandia  
National Laboratories, and Samuel Edwards, Naval Air  
Weapons Station, China Lake, California

*Presented at the 26th IEEE Photovoltaic  
Specialists Conference, September 29-  
October 3, 1997, Anaheim, California*



Sandia National Laboratories  
Photovoltaic Systems Department  
Post Office Box 5800  
Albuquerque, NM 87185-0753

Sandia is a multiprogram laboratory operated by Sandia Corporation, a  
Lockheed Martin Company, for the United States Department of Energy  
under Control DE-AC04-94AL85000.

September 1997

# THE U.S. ARMY YUMA PROVING GROUND 900-KVA PHOTOVOLTAIC POWER STATION

Roch Ducey, U.S. Army Construction Engineering Research Laboratories, Champaign, IL  
Richard Chapman, Sandia National Laboratories, Albuquerque, NM  
Samuel Edwards, Naval Air Weapons Station, China Lake, CA

## ABSTRACT

In the early spring of 1997, a 900-kVA, utility-tied photovoltaic power station was installed at the U.S. Army Yuma Proving Ground (YPG), in the southwest corner of Arizona (see Fig. 1). The system will be used to offset peak demand and serve as an emergency power system for YPG's water treatment plant. The power station includes 450-kWp of Siemens M-55 modules, 5600-kWh of C&D motive power batteries (see Fig. 2), and a 900-kVA power processing (see Fig. 3) and control system from Trace Technologies. Enhanced by the battery load leveling system, the power station has the capacity to reliably provide from 450- up to 825-kVA to YPG's utility grid during the summer peak demand season. The YPG system has three basic operating modes: (1) daytime utility-tied, (2) nighttime utility-tied, and (3) stand-alone. The amount of power delivered to the grid is governed by either available power from the PV array or by a power level defined by the user, whichever is greater.

## INTRODUCTION

Yuma Proving Ground had a ribbon-cutting ceremony for its 900-kVA Photovoltaic Power Station, on March 25, 1997. The celebration marked the culmination of

exactly five years of planning and working towards having this unique system installed. A number of U.S. Department of Defense (DoD) and Department of Energy (DOE) agencies have been directly involved with the project's implementation, since the initial concept development meeting on March 26, 1992 [1]. The original design was simply a 150-kWp grid connected array, but has increased significantly in size and function.

The final design includes a one-axis tracking system (see Fig. 4) and the capability of operating in an isolated-grid, stand-alone mode. Battery load-leveling equipment was also integrated into the system, which includes an additional 450-kVA of power processing capacity [2]. This enhancement nearly doubles the plant's peak-shaving capacity from 450 to 825-kVA, ensures a minimum peak-shaving capacity of 450-kVA during overcast or scattered cloud conditions, and provides back-up power to YPG's critical water treatment plant load, during utility outages [3].

## SYSTEM CONFIGURATION AND OPERATION

A block diagram of the YPG system (see Fig. 5) shows that the 900-kVA power processing system consists of two identical 450-kVA subsystems. Each 450-kVA subsystem consists of two 225-kVA inverter/rectifiers; a



Fig. 1. The 450-kWp (DC side) photovoltaic array at Yuma Proving Ground in Arizona

master and a slave. Each 225-kVA inverter/rectifier includes a 225-kVA PV maximum power tracker (MPT) and a 225-kVA bi-directional dc/dc converter for the battery. The MPTs and the battery dc/dc converters allow the inverter/rectifiers to operate at a higher voltage than the PV array and battery. In this case, the inverter/rectifiers operate at 750-Vdc while the PV array operates at a nominal 375-Vdc and the battery operates at a nominal 432-Vdc. The higher inverter/rectifier voltage increases both the efficiency and capacity of the inverter/rectifiers. The PV array and battery are divided into two halves. One half of the array and battery feed the master MPTs and battery dc/dc converters, and the other half feeds the slave MPTs and battery dc/dc converters. The operating mode determines which MPTs, battery dc/dc converters, and inverter/rectifiers operate at any one point in time.



Fig. 2. 5600-kWh of C&D motive power batteries.



Fig. 3. Trace Technologies power processing system.

### Operating Modes

The YPG system has three basic operating modes: (1) daytime utility-tied, (2) nighttime utility-tied, and (3) stand-alone. Whenever utility power is present, the system is either delivering power from the array and battery into the grid (daytime utility-tied mode), or drawing power from the grid to charge the battery (nighttime utility-tied

mode). The amount of power delivered to the grid is governed by either the available power from the PV array or by a power level defined by the user, whichever is greater. The user defines power levels via a programmable power profile.



Fig. 4. Single-axis tracking system [4].

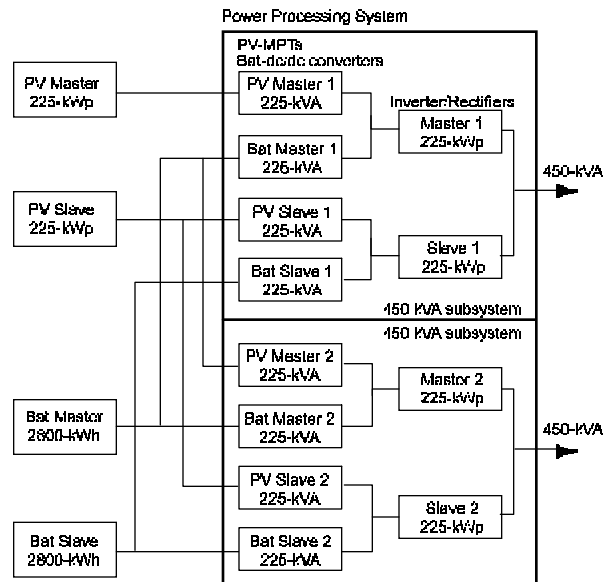

Fig. 5. Block Diagram

### Utility-Tied Modes

The operating modes are illustrated using a typical array power profile for a summer day in Yuma (see white bars in Fig. 6) and an example user power profile (see bold line in Fig. 6). Note that the array power profile is the ac power that can be derived from the available dc

power from the array. For this example, the user power profile is zero for hours 14 through 24 and hours 1 through 5, 450 kW for hours 10 and 11, and 750 kW for hours 12 and 13. This profile is used to tailor the output of the system to the site's demand characteristics. As stated above, the power delivered to the grid is the greater of the available PV power and the power profile defined by the user. The power delivered to the grid is defined by the available PV power (white bars) before hour 10 and after hour 13. In this mode, all battery dc/dc converters are inactive and only one 450-kVA subsystem is active (see Fig. 7a). Note that either master/slave pair 1 or 2 could be the active subsystem.

During hours 10 and 11, the user power profile calls for 450 kW. Only one 450-kVA subsystem is active for this mode, but the battery dc/dc converters (of the active 450-kVA subsystem) are activated to make up the difference between the available PV power and 450-kW (see Fig. 7b). Note that all array power is delivered to the grid and only the shortfall is drawn from the battery (see gray bars in Fig. 6). This direct use of the array power realizes the maximum possible benefit from the array.

The user power profile calls for 750-kW during hours 12 and 13. Both 450-kVA subsystems are active in this mode (see Fig. 7c). One subsystem processes the array power (the battery dc/dc converters are disabled), and the other subsystem processes the battery power. In this mode, one 450-kVA subsystem can deliver up to approximately 375-kVA from the array and the other 450-kVA subsystem can deliver up to 450-kVA from the battery for a total of 825-kVA delivered to the grid. The ability to dispatch the 450-kVA subsystems provides two benefits.

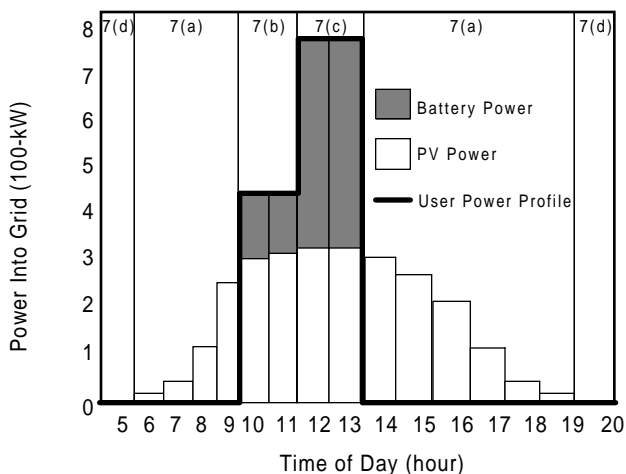

Fig. 6. Power to grid for Various Operating Modes.

First, the power processing system is operated at a higher loading, and therefore at higher efficiencies, at power levels below 450-kWac. In addition, the overall system life is increased by only operating both subsystems when needed.

The battery is then recharged from the utility at night. Both 450-kVA subsystems and all battery dc/dc converters can be activated to charge the battery (see Fig. 7c). The system is designed to provide a full battery

recharge each night. The power processing system is designed to provide a taper current charge once the battery reaches its float voltage level.

### Stand-Alone Mode

The power processing system will automatically switch from the utility-tied mode to the stand-alone mode in the event of a utility outage, and it will automatically switch back to the utility-tied mode when utility service is restored. In the event of a utility outage, the power processing system shuts down while the water treatment plant is electrically isolated from the utility grid. The power processing system restarts in a stand-alone mode with the same component configuration as the daytime utility-tied mode (user profile less than PV power). Only one of the 450-kVA subsystems can operate in the stand-alone mode at a time (see Fig. 7b). If the available PV power exceeds the power demand of the water treatment plant, the excess PV power is used to charge the battery through the battery dc/dc converters.

### System Controller

The controller is based on a system of microprocessors. Distributed processors monitor and interface with the subsystems, while a personal computer (pc) collects and analyzes the system status data and then determines the appropriate operating mode for each subsystem. The implementation of the actual subsystem operation of the PV power station is internal to the power processing system. (The isolation of the water treatment plant is implemented by a remote isolation switch.)

For example, during battery charging the pc will collect the battery temperature, current, and voltage, determine the appropriate charge current at that point in time, and then instruct the power processing system to charge the battery at that current. The pc provides manual system control and is used to modify the user power profile and system set points, display system status, and archive performance data. The system can be controlled from a remote computer as well.

### CONCLUSIONS

The implementation of this project was only possible because of some unique circumstances. In the near future, it is not likely that more utility-tied PV powerplants will be installed at other DoD installations. Nevertheless, this project has significantly advanced systems integration and power conditioning technologies, to a point that more large-scale, isolated-grid PV/diesel hybrid powerplant applications can be identified and implemented within DoD. There are many off-grid DoD facilities, which could take advantage of the benefits that these systems have to offer. The success of this project will also raise awareness within the DoD community of the many mature PV system technologies, already available fortens of thousands of cost-effective applications at their facilities.

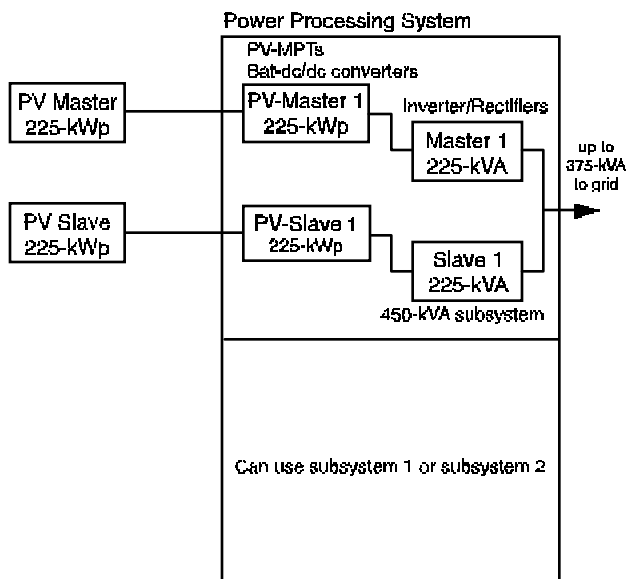

(a) daytime utility-tied mode, with PV power greater than user profile.

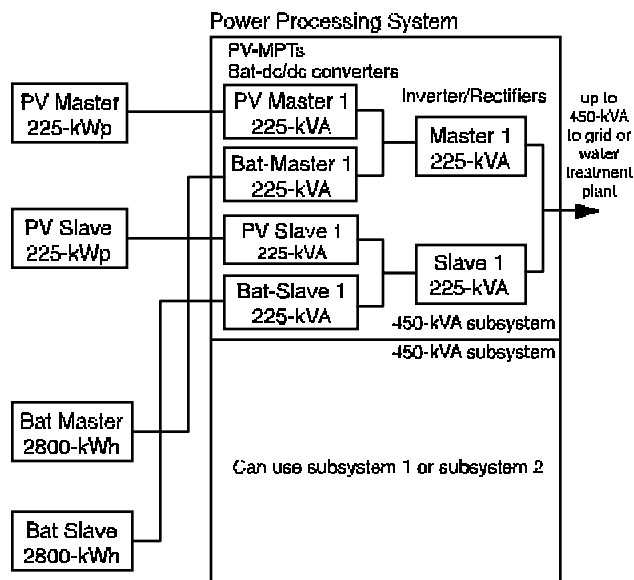

(b) daytime utility-tied mode, with user profile (less than 450-kVA) greater than PV power, and stand-alone mode.

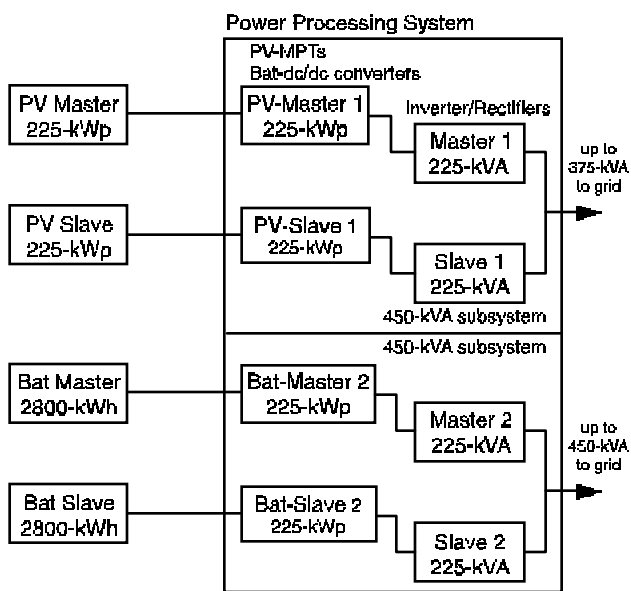

(c) daytime utility-tied mode, with user profile (greater than 450-kVA) greater than PV power.

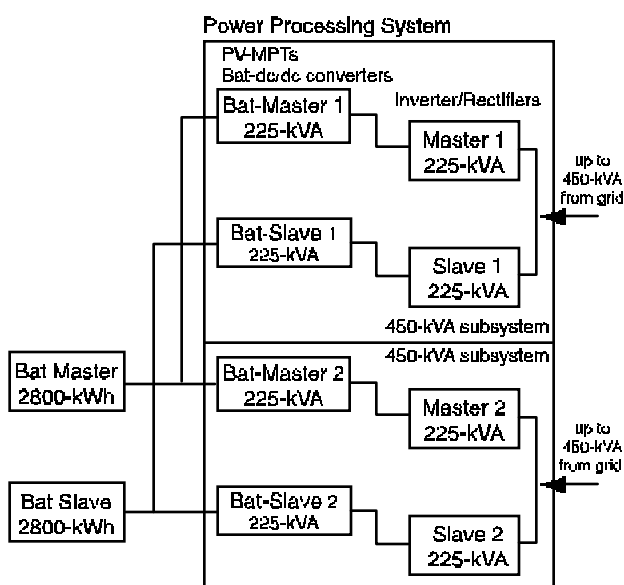

(d) nighttime utility-tied mode for battery charging.

Fig. 7. Operating Modes for the Yuma roving Ground 900-kVA Photovoltaic Power Station.

## REFERENCES

[1] R. Ducey, "Yuma Proving Ground Plugs Into the Sun," FEMP Focus, June 1997, p. 15.

[2] R. N. Chapman, "Photovoltaics in the Department of Defense," 14th NREL/SNL Photovoltaics Program Review, American Institute of Physics Conference Proceedings 394, 18-22 November 1996, pp 491-511.

[3] R. N. Chapman, "Hybrid Power Technology for Remote Military Facilities," Ninth International Power Quality Solutions/Alternative Energy Conference: Power System World '96 Conference and Exhibit, 9-13 September 1996, pp. 415-427.

[4] M.J. Stern and R.T. West, "Development of a Low-Cost 15 kW A.C. Solar Tracking Sub-Array for Grid-Connected PV Power Applications," Twenty Fifth IEEE PVSC, 1996, pp. 1369-1372.